



DEUTZ Australia PTY LTD
136-140 South Park Drive, Dandenong South, Victoria, 3175

DEUTZ Asia-Pacific (PTE) LTD
10 Gul Crescent - Singapore 629523

DEUTZ DPS GENERATING SETS

OPERATION AND MAINTENANCE MANUAL

Introduction

Thank you for having purchased a DEUTZ DPS generating set.

This document applies to all DEUTZ DPS generating sets. We recommend you read this manual carefully and comply with the standards relative to safety and correct operation and maintenance of the generating set. Should any doubts arise while reading the manual or using the unit, please contact a DEUTZ technician. The information contained herein is correct at the time of printing but can be changed without prior notice or notification, in line with our objectives of continuous product development and improvement.

This manual, together with the engine and alternator manuals and other documents delivered with the unit, are an integral part of the "DEUTZ DPS Generating Set" (hereinafter called genset). Please note that in case of different instructions in the manuals, those to be complied with and applied must be the safest and strictest.

This manual and the attached documentation are intended to be consulted by all those involved in the life cycle of the unit and must therefore, always be kept and made accessible to the user.

The generating set can only be installed and used after having read this manual completely and complying with the instructions therein.

Table of Contents

INTRODUCTION	- 1 -
1. SAFETY INSTRUCTIONS.....	- 3 -
1.1. SAFETY SIGNS	- 3 -
1.2. PERSONAL PROTECTIVE EQUIPMENT (PPE).....	- 4 -
1.3. RESIDUAL RISKS	- 4 -
2. PLATE DATA	- 6 -
3. GENERAL DESCRIPTION.....	- 7 -
4. GENERAL CONDITIONS OF USE OF THE GENERATING SET.....	- 8 -
4.1. PERMITTED MACHINE USE	- 8 -
4.2. UNAUTHORISED MACHINE USE	- 8 -
4.3. WARNINGS REGARDING THE USER SYSTEM.....	- 8 -
4.3.1. <i>Single-phase loads</i>	- 8 -
4.3.2. <i>Non-linear loads</i>	- 8 -
4.3.3. <i>Resistive loads</i>	- 8 -
4.3.4. <i>Capacitive loads</i>	- 8 -
4.3.5. <i>Load application method</i>	- 8 -
5. HANDLING THE GENERATING SET.....	- 9 -
5.1. GENERAL PRECAUTIONS WHEN HANDLING THE UNIT	- 9 -
5.2. HANDLING METHODS	- 9 -
5.2.1. <i>Handling with a fork lift</i>	- 9 -
5.2.2. <i>Handling with ropes or chains</i>	- 9 -
5.2.3. <i>Transporting on a vehicle</i>	- 10 -
6. INSTALLATION INSTRUCTIONS	- 11 -
6.1. GENERAL REQUIREMENTS FOR INSTALLATION	- 11 -
6.2. OUTDOOR INSTALLATION	- 11 -
6.2.1. <i>Requirements for the place of installation</i>	- 12 -
6.2.2. <i>Safety distances</i>	- 12 -
6.2.3. <i>Protective guard</i>	- 12 -
6.3. INDOOR INSTALLATION.....	- 12 -
6.3.1. <i>Dimensions of the room</i>	- 12 -
6.3.2. <i>Flooring</i>	- 12 -
6.3.3. <i>Openings and ventilation in the room</i>	- 12 -
6.3.4. <i>Exhaust pipe</i>	- 13 -
6.3.5. <i>Oil vent</i>	- 13 -
6.3.6. <i>Noise level in an indoor installation</i>	- 13 -
6.4. ELECTRICAL CONNECTION	- 13 -
7. COMMISSIONING AND START-UP.....	- 15 -
7.1. COMMISSIONING	- 16 -
7.2. INSPECTIONS TO BE PERFORMED BY THE USER	- 17 -
7.3. STARTING UP AND STOPPING.....	- 18 -
8. MAINTENANCE	- 19 -
8.1. GENSET MAINTENANCE.....	- 19 -
8.2. PERIODIC OPERATION TEST	- 20 -
8.3. TROUBLESHOOTING	- 20 -
9. REQUESTING ASSISTANCE.....	- 21 -
10. STORAGE INSTRUCTIONS	- 21 -
11. DISPOSAL INSTRUCTIONS	- 21 -

1. Safety instructions

The generating set is a unit intended to be used by duly trained personnel. The installation must be solely planned and carried out by qualified technicians. Errors when installing or using the unit can seriously damage the user system, the unit itself or injure those involved.

1.1. Safety signs

Hereunder are the safety symbols applied to the unit and their meaning so as to facilitate understanding and the maintenance required.

	The motor becomes hot during operation. Do not touch while the genset is running or soon after it is stopped. Risk of burns. Do not store combustible material near the generating set: risk of fire.
	Parts move very fast: do not remove the protections: risk of cutting or shearing.
	There can be hazardous voltages inside the electrical panel and the alternator even with the generating set switched off . Therefore, the panels must be opened and wires connected solely by qualified personnel.
	The earth connection is important for safety purposes. It is compulsory to connect the generating set before being used. This must be implemented by a specialised technician.
	All the liquids used in the motor are harmful and must not be swallowed; avoid direct contact with the body. The electrolyte of the starter battery contains sulphuric acid: if contact is made, immediately rinse with running water and seek medical advice. Vapours can leak from the starter battery, which can explode if they make contact with fire.
	Attention: the generating set can start-up automatically. Switch the control panel off before intervening on the generating set. The symbol is only found on self-starting units (manual with autostart, automatic, with In-sync control unit, etc).
	Parts or areas of the unit that may be potentially dangerous, or indicate points where to pay attention if contact is made, removal of the protections, opening the panels, etc.
	Do not inhale the exhaust gas: they contain harmful substances that can cause intoxication and death when highly concentrated.
	The coolant is toxic. Top-up in a ventilated area, with the unit stopped and the motor cold. Avoid direct contact with the body and do not inhale the vapours. Do not remove the cap of the radiator before the liquid has cooled down. Loosen the cap slowly to prevent splashes due to any excess pressure.
	The fuel is flammable and toxic. Top-up in a ventilated area, with the unit stopped and the engine cold, avoid direct contact with the body and do not inhale the vapours. Do not smoke and do not use open flames.
	The set-up of certain units may require temporary works to be carried out at a height during the handling, installation or maintenance operations. Do not climb on the GENSET. Choose the most suitable equipment to guarantee and maintain safe work conditions, in accordance with applicable regulations.
	Before approaching the unit in operation, wear the relative ear protectors so as to prevent possible harm to your hearing.
	Identifies the emergency stop button.
	The ropes must only be hooked at the points indicated by the symbol at the side.
	The forking area is indicated by the symbol at the side.
	Carefully read this manual. Comply with the safety standards and correct operation and maintenance of the generating set. Should any doubt or misunderstanding arise while reading the manual or using the unit, please contact a DEUTZ technician.
	Disable the starting device in self-starting units before performing any maintenance. Disconnect all the sources of power from the electrical panel in units equipped with a battery charger, pre-heating system or automatic board.
	Identifies the fixed protections. If these must be removed, they must be set back into place before starting the unit.
	Do not use water in case of fire.

	Do not smoke near the GENSET.
	Do not use open flames near the GENSET.
	Do not clean, lubricate, repair or adjust moving parts manually. All maintenance and inspection operations must be performed with the unit blocked, the motor cold and after having disconnected the unit from all external sources of power.
	Access to unauthorised persons is forbidden.

1.2. Personal protective equipment (PPE)

	Wear safety shoes.		Wear safety goggles.
	Wear close-fitting clothes.		Wear ear protectors.
	Wear gloves.		

1.3. Residual risks

The generating set is a unit that converts thermal energy of the fuel into electrical energy and therefore poses risks related to both types of energy: although DEUTZ gensets are equipped with a number of active and passive safety devices that make them safe during their normal use, there lie residual risks, during the handling, maintenance, installation and deinstallation operations, due to their intrinsic nature.

The residual risks related to the unit are summarised below.

Supply battery: risk of corrosion, explosion.
Do not smoke, do not use open flames, do not produce sparks near the batteries.

Exhaust end part: risk of burns, chemical.

Handling area: risk of crushing. Prohibit access to the operating radius of the handling machines.
Pay attention to the handling operations near overhead power lines.

The electrical connections must be implemented by qualified personnel and according to standards. Pay attention to cable dimensioning and to the earthing of the machine.

The genset may start-up automatically in self-starting units.
Switch the unit off and prevent it from being started up before intervening.



Chemical risk due to contact made with diesel, oil, coolant or electrolyte.



Risk deriving from noise, in units distinguished by $Leq \geq 80$ dBA.



The fuel is flammable and toxic.
 Top-up in a ventilated area, with the unit stopped and the engine cold. Do not smoke and do not use open flames. Do not smoke, do not use open flames, do not produce sparks near the fuel or other inflammable liquids.
 Pay utmost attention during the topping up to not disperse fuel.
 Do not top up fuel tank over its nominal capacity.
 Do not operate the generating set in any presence of leakages.



Improper disposal of waste may be harmful for the environment.
 Harmful liquids and the other harmful materials must be disposed according to local laws and regulations.
 Suitable containers must always be used.
 Do not disperse in the environment.



2. Plate data

 Generating Set ISO 8528		
Item		
Serial Nr.		
Model		
Type		
Manufacture Year		
Electrical Equipment		
PRP Power (kVA)		
PRP Power (kW)		
Voltage (V)		
Ampere (A)		
Frequency (Hz)		
Power factor		
Speed RPM		
Phases		
Governor class		
Weight (kg)	DRY	WET
Site Temp. °C		
Altitude (m)		
DEUTZ Australia PTY LTD 4/ 13-15 Brough St - Springvale, Victoria Phone No. +61 3 9549 8400 - www.deutz.com.au		

 Generating Set ISO 8528		
Item		
Serial Nr.		
Model		
Type		
Manufacture Year		
Electrical Equipment		
PRP Power (kVA)		
PRP Power (kW)		
Voltage (V)		
Ampere (A)		
Frequency (Hz)		
Power factor		
Speed RPM		
Phases		
Governor class		
Weight (kg)	DRY	WET
Site Temp. °C		
Altitude (m)		
DEUTZ Asia-Pacific (PTE) LTD 10 Gul Crescent - Singapore 629523 Phone No. +65 6672 7800 - www.deutz.com.sg		

Note:

Dry: weight without fuel

Wet: weight with fuel

3. General description

The generating set is a unit intended to produce electric power by means of an alternator, which is set to rotate by a diesel motor. The installation, connection and maintenance require adequate preparation on the intrinsic risks of the unit. Errors when installing or using the unit can seriously damage the user system, the unit itself or injure those involved. Hereunder is a list of the main components of the generating set.

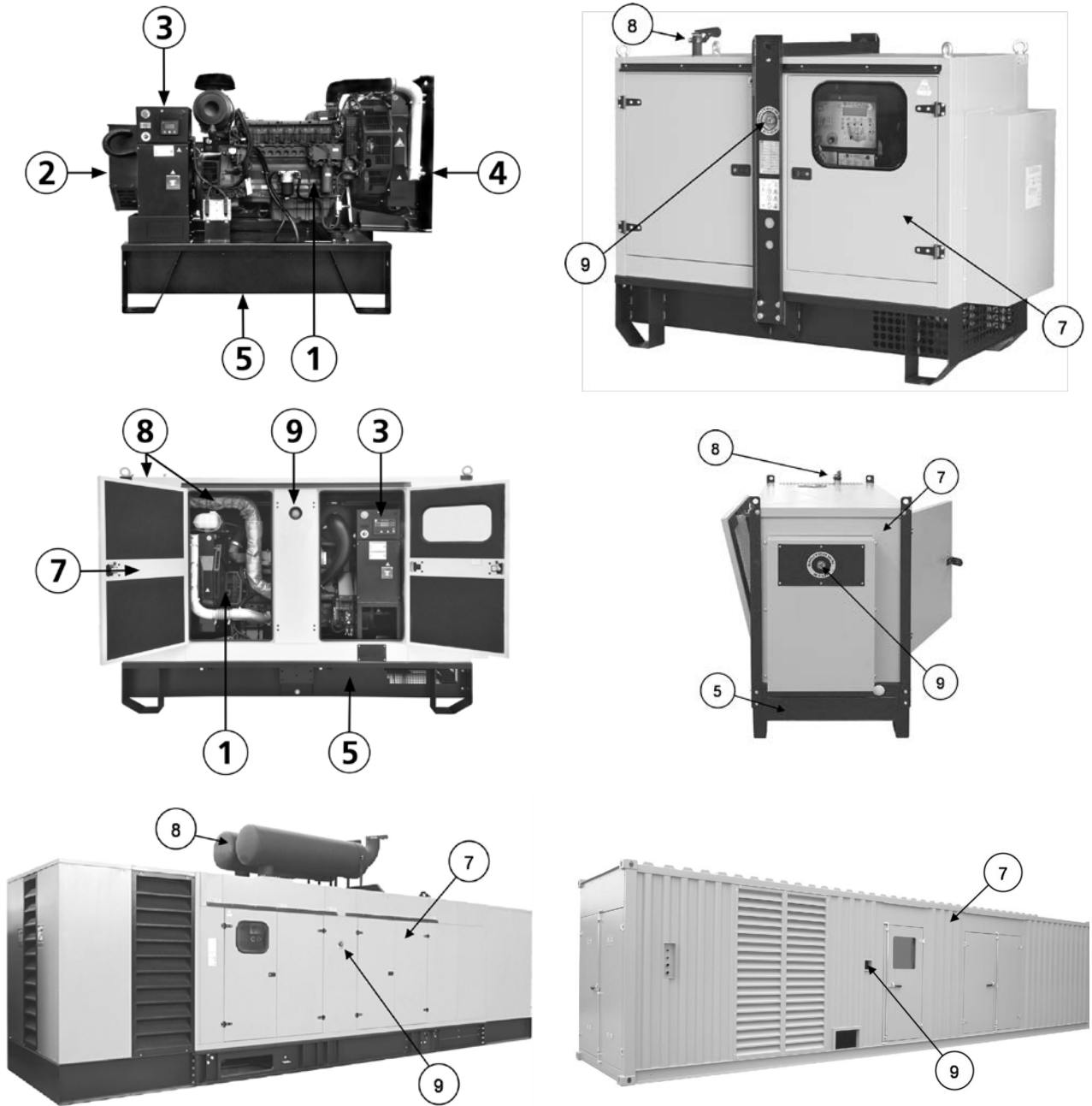

- | | | |
|-----------------|----------------------|--------------------|
| 1 Motor | 4 Radiator | 7 Canopy |
| 2 Alternator | 5 Base frame/tank | 8 Silencer |
| 3 Control panel | 6 Protective grilles | 9 Emergency button |

fig. 1

The motor ①, powered by diesel in the tank ⑤ sets the alternator ② in rotation, which produces electric power. The electric current from the alternator passes to the electrical panel ③ where there is the main safety switch and control logic.

As the motor runs, it generates heat that is disposed of through the radiator ④. The exhaust gases pass through the exhaust line protected by the grille ⑥ and expelled by the silencer ⑧.

All the above is enclosed in the canopy ⑦ (optional), which protects against the elements when installed outdoors and reduces the noise.

The unit's emergency stop button ⑨ is found on the control panel as well as the canopy.

It must be noted that every genset is built with characteristics and equipment defined when the contract is compiled. Your specific unit may or may not have the same features, shapes and components as those shown in this manual.

4. General conditions of use of the generating set

4.1. Permitted machine use

DEUTZ DPS gensets are intended for a fixed use, which is continuous or in an emergency, to supply power to civil or industrial systems. Any other use must be approved by DEUTZ.

The unit can only be used if the following are complied with:

- all the requirements pertaining to installation, operation and maintenance indicated in the manuals supplied
- all the requirements regarding compliance with applicable laws in the place of installation.

The unit can be used in accordance with the plate data related to the environmental conditions specified in ISO8528-1, and the class of use: COP (continuous with a constant load), PRP (continuous with a variable load) or LTP (emergency use at ≤ 500 hours/year); the standard performance levels of the unit refer to temperatures ranging from +10 to +35°C, an altitude ranging from 0 to 500m and degree of humidity ranging from 0 to 60%. Using the unit in different conditions leads to a declassification or specific accessories having to be installed.

Conformity with the Directive regarding sound power and that regarding emission levels is required by gensets with a power < 400 kW when used as mobile units in member states of the EEC. Only models bearing the suffix **VM** on the plate are compliant.

If the genset is to be used in severe conditions, in terms of performance or particularly dusty or harsh work environments, the unit requires special equipment and specific maintenance cycles. Contact DEUTZ.

4.2. Unauthorised machine use

It is not allowed to use the unit in any way other than that specified in paragraph 5.1

It is not allowed to use the unit in environments classified according to Directive 99/92/EC (environments with risk of explosion, etc).

It is not allowed to use the unit mobile unless strictly specified (refer to paragraph 4.1).

It is not allowed to use fuel that does not comply with EN 590 (biodiesel or similar).

It is not allowed to use the unit in particularly critical emergency situations (danger to life), without having first carried out a thorough analysis of the conditions of use and the risks.

It is not allowed to use the unit without the required authorisations and/or compliance with laws and regulations applicable in the place of installation.

4.3. Warnings regarding the user system

The characteristics of the equipment to be supplied can affect the proper operation of the generating set. There are user appliances that can be supplied by the generating set only if the power is much lower than the rated power.

4.3.1. Single-phase loads

The single-phase cannot exceed 1/3 of the rated power or the unit in the case of three-phase gensets. The tolerance is not guaranteed on the output voltage if an individual single-phase or highly unbalanced load is powered with a three-phase genset. This type of use is not recommended.

4.3.2. Non-linear loads

The most common non-linear loads are devices used to control the speed in electric motors (soft-start), uninterruptible power supply units (UPS), equipment with SCR and discharge lamps.

Make sure the generating set has been sized correctly before starting up

Non-linear loads can cause a malfunction when adjusting the voltage, thereby damaging the alternator and the powered systems.

4.3.3. Resistive loads

When using a genset with a purely resistive load, you must consider that the apparent power (kVA) and the actual power (kW) coincide (since $\cos\phi$ is equal to 1.0). Therefore, the electrical load must be 20% lower than the rated power in kVA of the unit.

4.3.4. Capacitive loads

More often than not the capacitive loads consist of capacitor banks. Particular attention must also be paid to electronic static welders and discharge lamps. A generating set can power a capacitive load for a maximum value equal to 20% of the rated power of the alternator

4.3.5. Load application method

The maximum load that can be applied to a generating set in a single entry is generally around 60-70% of the rated power. It is highly recommended to distribute the load entry in at least 2-3 steps. Contact DEUTZ for further information.

Do not let the generating set run for prolonged periods of time at the minimum speed or at a low load as this can cause a malfunction and damage the unit. If in doubt, contact DEUTZ.

5. Handling the generating set

DEUTZ DPS generating sets are equipped with specific points to lift the unit and for its un/loading operations. Even though this equipment is present, the standard unit configuration is designed for fixed use (not mobile).

	<p>Due to the high mass of the genset, an error during the handling process can seriously damage the genset or harm people. Do not stop within the operating radius of the handling vehicle. Verify that the lifting points are intact before commencing the operations. The lifting operations are hazardous and must always be carried out with utmost safety and in full compliance of all the applicable regulations.</p>
--	--------------------------------------------------------------------------------------------------------------------------------------------------------------------------------------------------------------------------------------------------------------------------------------------------------------------------------------------------------------------------------------------------------------------------------------

5.1. General precautions when handling the unit

- Handling operations must always be carried out with the motor switched off and an empty tank (this must be emptied with equipment and methods that comply with all the applicable regulations), disconnected power lines, disconnected starter battery (open the battery cut-off switch) and the electrical panel switched off (key in "OFF" position and removed).
- A few parts of the motor retain heat even after being switched off: wait for the genset to cool down before covering them in order to prevent the risk of fire.
- It is prohibited to attach objects or accessories on the base frame of the generating set, which weigh down on the unit.
- The handling operations must be carried out with utmost care when the unit is lifted.**

5.2. Handling methods

5.2.1. Handling with a fork lift

When a fork lift is used for the handling operations it is compulsory to fork the base frame from the side and let the forks protrude on each side, widening them as much as possible so as to distribute the weight. Do not exceed the maximum inclination of 10°.

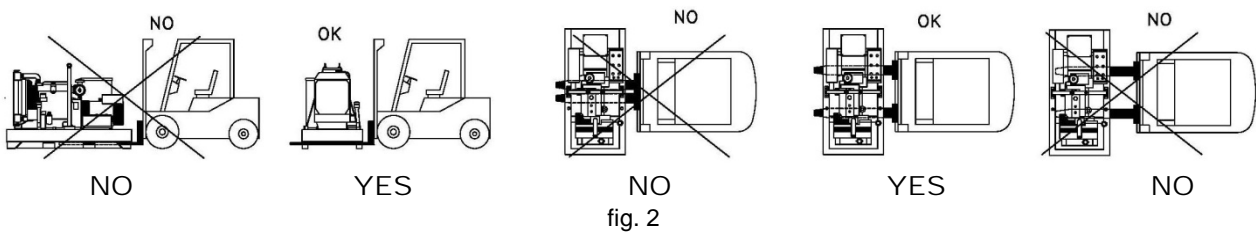

	<p>The forking area is indicated by the symbol at the side.</p>
--	-----------------------------------------------------------------

5.2.2. Handling with ropes or chains

	<p>The ropes must only be hooked at the points indicated by the symbol at the side. Make sure the chains/ropes are as vertical as possible. It is forbidden to climb on the unit to reach the lifting points.</p>
--	-------------------------------------------------------------------------------------------------------------------------------------------------------------------------------------------------------------------

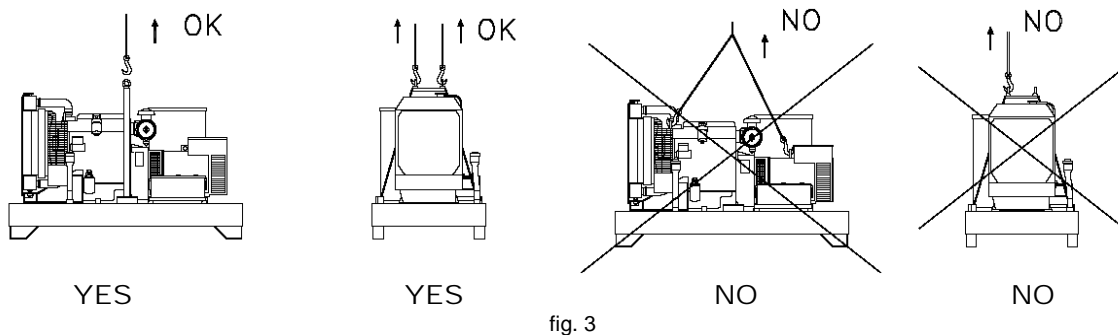

The chains/ropes must be inclined a maximum of 30° with respect to the upright position in generating sets with 4 anchor points. In any case, make sure the chains/ropes are as vertical as possible.

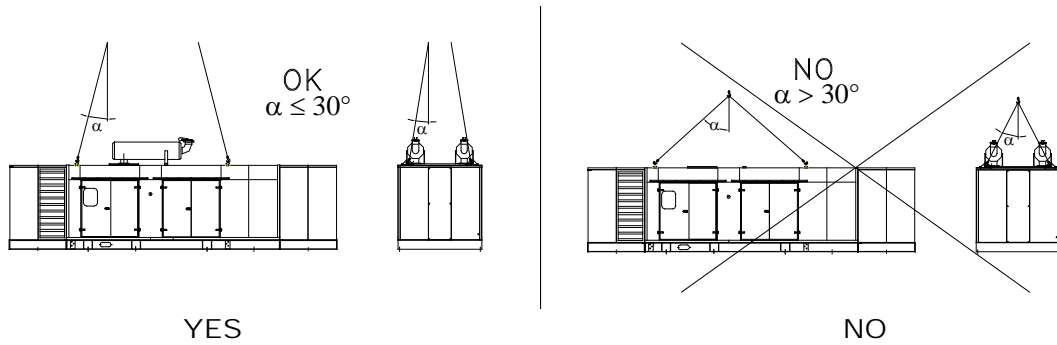

fig. 4

Certain units require temporary works at a height for the lifting points to be accessed. Choose the most suitable equipment to guarantee and maintain safe work conditions, in accordance with applicable regulations. Evaluate using ladders or scaffolding for a work station at a height, as well as the use of ropes for access and positioning systems.

Do not climb on the radiator, motor, alternator, canopy or the control panel.



YES



NO

5.2.3. Transporting on a vehicle

When transporting on a vehicle, fasten the unit to the flatbed to prevent knocks or jolts, which could cause the load to move. Set the base frame as a support to the structural parts of the truck. Do not use motor parts, the alternator or the control panel to fasten the genset.

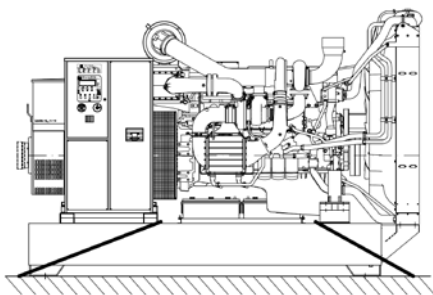

YES

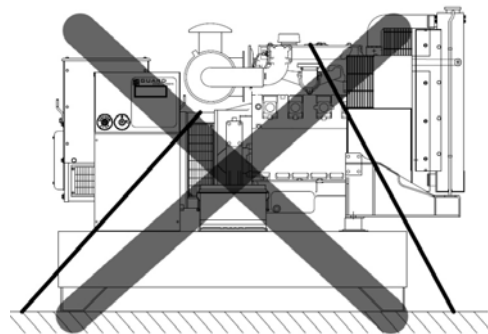

NO

In the case of units with a canopy, pass the fastening belts behind the protruding parts or through the lifting hooks.



YES

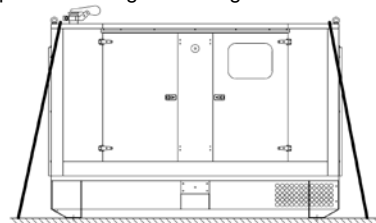

YES

6. Installation instructions

6.1. General requirements for installation

The installation must be implemented by qualified technicians as errors can cause malfunction, damage to the unit or to the user's system or injury to those involved.

Verify all the following conditions:

- the genset has been appropriately selected according to the requirements of the electrical load and the environmental operating conditions (temperature, altitude and humidity);
- the base is positioned in an area where it can never be submerged in water, not even partially (if water is drawn, it could seriously damage the genset);
- the problems regarding safety of the supervision and management personnel of the unit have been evaluated;
- management personnel have been trained and have read and understood the manuals of the genset and the user's systems;
- a thorough analysis has been carried out on the problems related to noise emission;
- a correct analysis of the fuel storage and lubricating oil requirements has been carried out according to the applicable regulations in the place of installation;
- all the authorisations required by applicable laws in the place of installation have been requested.

	<p>Depending on the specific place where the machine is installed, different laws and regulations apply. Check all the legal requirements and the authorizations needed for installing the machine. All local and national laws of the place of installation have priority over what is reported in this manual: in case of conflicting provisions between the manual and local regulations, contact DEUTZ. Evaluate carefully all the aspects related to local regulations regarding acoustic zoning, seismic, electrical installation, fuel storage, emissions into the atmosphere, etc ...</p>
--	---------------------------------------------------------------------------------------------------------------------------------------------------------------------------------------------------------------------------------------------------------------------------------------------------------------------------------------------------------------------------------------------------------------------------------------------------------------------------------------------------------------------------------------------------------------------------------------------------

	<p>Certain installations, depending on the type of unit, may require temporary works to be carried out at a height. Choose the most suitable equipment to guarantee and maintain safe work conditions, in accordance with applicable regulations. Evaluate using ladders or scaffolding for a work station at a height, as well as the use of ropes for access and positioning systems.</p>
--	---------------------------------------------------------------------------------------------------------------------------------------------------------------------------------------------------------------------------------------------------------------------------------------------------------------------------------------------------------------------------------------------

	<p>Do not climb on the radiator, motor, alternator, canopy or the control panel.</p>
--	--------------------------------------------------------------------------------------

Prevent the unit generating set from coming in contact with dust, especially if saline. If the radiator or the intake filters are clogged with particles in the air, there lies the risk that the generating set overheats and is damaged. Make sure that the intake grilles are not obstructed with leaves, snow or other material.

The installation platform must be adequately rigid and isolated from vibrations to other structures and have a mass that is at least three times that of the generating set.

Do NOT position the generating set on a terrace or a raised floor that is not adequately sized and verified.

The genset is delivered with the rain cap loose. It is compulsory to assemble it in order to prevent water from entering the exhaust silencer.

	<p>The generating set must be installed in a way that the exhaust gases disperse in the air without being inhaled or reaching persons or living creatures. The exhaust gases contain harmful substances that can cause intoxication and death when highly concentrated. Comply with the requirements of law in the place of installation.</p>
--	-----------------------------------------------------------------------------------------------------------------------------------------------------------------------------------------------------------------------------------------------------------------------------------------------------------------------------------------------

Do not hesitate to contact DEUTZ for any doubt you may have regarding the installation.

6.2. Outdoor installation

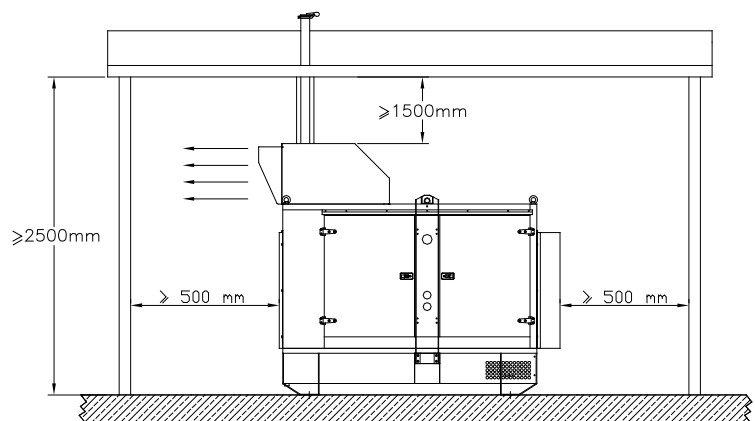
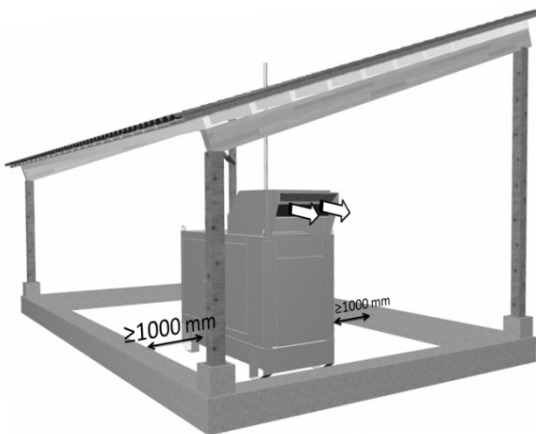

fig. 5
Example of outdoor installation with shelter

6.2.1. Requirements for the place of installation

It is forbidden to install a unit outdoors without the canopy (M, B, GO and U versions); these units must be installed in closed areas away from atmospheric agents.

6.2.2. Safety distances

The genset must be placed at a safe distance from fuel deposits, flammable material and chemicals: these distances are stipulated by the relevant authorities in the place of installation.

Prevent unauthorised persons from going near the generating set, especially in places with public access.

6.2.3. Protective guard

In case of outdoor installations where particularly harsh weather conditions might occur (e.g. heavy snowfall with the formation of ice, positioning on docks exposed to coastal storms, etc.), we recommend the construction of a shelter that reduces the effects of the elements on the generating set. The protective guard of the genset must not be bound to the unit itself (see fig. 5).

	The motor and alternator generate while running:
	▪ the guard used must not block the components from cooling;
	▪ The exhaust gases must be conveyed so as not to be drawn by the motor fans or the alternator;
	▪ The covering materials must be fireproof.

6.3. Indoor installation

ref.	Description
1	Generating set
2	Auxiliary extractor
3	Control panel
4	Exhaust silencer
5	Exhaust duct
6	Dilation compensator
7	Protection and insulation of exhaust duct
8	Rain cap or anti-intrusion cap
9	Air extraction duct
10	Air duct anti-vibration joint
11	Platform with insulated foundation
12	Air inlet with anti-intrusion mesh
13	Containment step

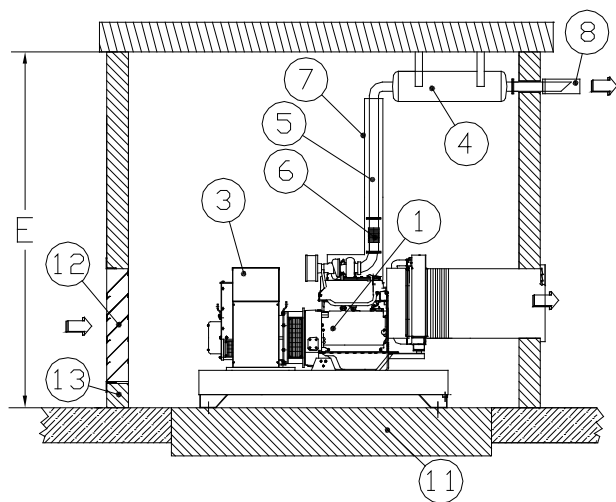

Recommended minimum dimensions table	
A	Genset length + 1000 mm
B	Genset width + 2000 mm
C	Genset length + 400 mm
D	Genset width + 400 mm
E	Genset height + 1500 mm (>2500 mm)
N.B.: however, the minimum distances between the generating set and the walls of the room must be complied with as stipulated by applicable laws	

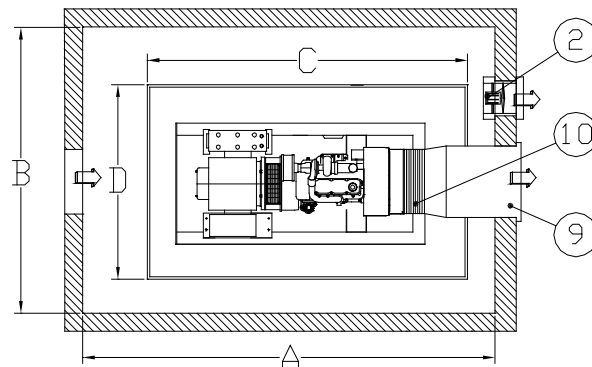

Fig. 6

6.3.1. Dimensions of the room

Carefully verify all the following conditions:

- The room is adequately sized to allow access to the motor and the generator for routine maintenance and any repairs (on at least 3 sides);
- the openings of the room allow a sufficient air flow for combustion and for the unit to cool down;
- an adequate extraction line is designed and set up for the exhaust gases in the room.

6.3.2. Flooring

The unit is designed not to cause excessive vibrations and is equipped with anti-vibration mounts for this purpose. Contact DEUTZ for particular installations (e.g. on floors).

6.3.3. Openings and ventilation in the room

The room must have a sufficient ventilation system to dispose of the heat generated by the genset during operation, excluding the possibility of stagnation or recycling the overheated air.

The inlet and extraction openings of the combustion and cooling air must be sized taking into consideration the minimum flows and the maximum back-pressures indicated in the specific technical documentation. In any case, the size of the openings must be calculated by comparing the residual pressure at the radiator and the counter-pressure back-pressure created by the conveyor that may be installed.

	<p>ATTENTION: Install an air expulsion as indicated in detail 9 of fig. 6 to prevent recirculation of hot air between the radiator and the wall extraction opening and allow access to the radiator for maintenance purposes.</p>
--	------------------------------------------------------------------------------------------------------------------------------------------------------------------------------------------------------------------------------------------

6.3.4. Exhaust pipe

Remember that exhaust gases are hazardous for one's health and must not be inhaled. The minimum requirements for the pipe are:

- minimum thickness: 3 mm;
- diameter according to the length, number of bends and type of exhaust silencer on the line: the back-pressure along the pipe must not exceed the value indicated in the specific technical documentation. **Excessive back-pressure causes a loss in capacity, overheating and damage to the motor;**
- the exhaust line must be connected to the motor with a compensation joint to absorb the thermal expansion and vibrations;
- the motor exhaust line must not bear its weight on the manifold of the motor;
- the exhaust line, at least in the sections inside the room, must be externally insulated to reduce irradiation; on the contrary, the engine turbine must never be insulated to avoid overheating;
- the exhaust line must be kept away from where persons or animal pass for the exhaust not to reach them.

6.3.5. Oil vent

The motor oil vent (if present) must be connected outside the room for the emitted oil vapours not to dirty the motor and the radiator. The pipe must be installed with an inclination so as to prevent pockets of condensation from clogging the vent. The vent must be kept away from where persons or animal pass for the vapours not to be inhaled or be condensed, thereby posing the risk of slipping and/or pollution.

6.3.6. Noise level in an indoor installation

The residual external noise level in the case of gensets installed in closed areas depends on the installation conditions and must be ≤ the limits stipulated by applicable laws and regulations. Installing a unit in a room leads to an increase in the noise pressure level caused by the conditions surrounding the installation itself (reverberation, amount of noise, etc.). Perform the necessary evaluations and apply the relative personal protective equipment.

6.4. Electrical connection

An incorrect electrical connection could seriously damage the genset, the connected systems and injure those involved.

	<p>There can be hazardous voltages inside the generating set even if it is switched off: do not start-up, perform maintenance, repairs or alterations without specific knowledge.</p>
--	---------------------------------------------------------------------------------------------------------------------------------------------------------------------------------------

- Before connecting the system always verify that the system to be powered is compatible with the genset; pay particular attention to Chapter 1 and 4;
- consult the wiring diagram below and the specific manuals of the protection devices, switching devices, etc.;
- verify that the earth connection is efficient by making sure the direct and indirect contact protection systems work well and are coordinated: risk of electric shock.
- Genset with earth fault protection have neutral connected to earth. Gensets without earth fault protection have insulated neutral, in this case evaluation of neutral earthing is responsibility of the installer.

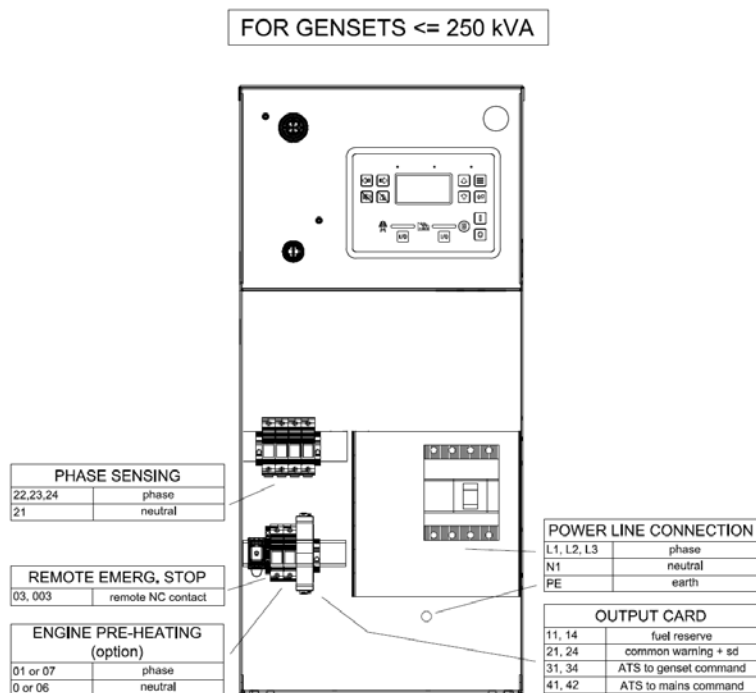

FOR GENSETS > 250 kVA

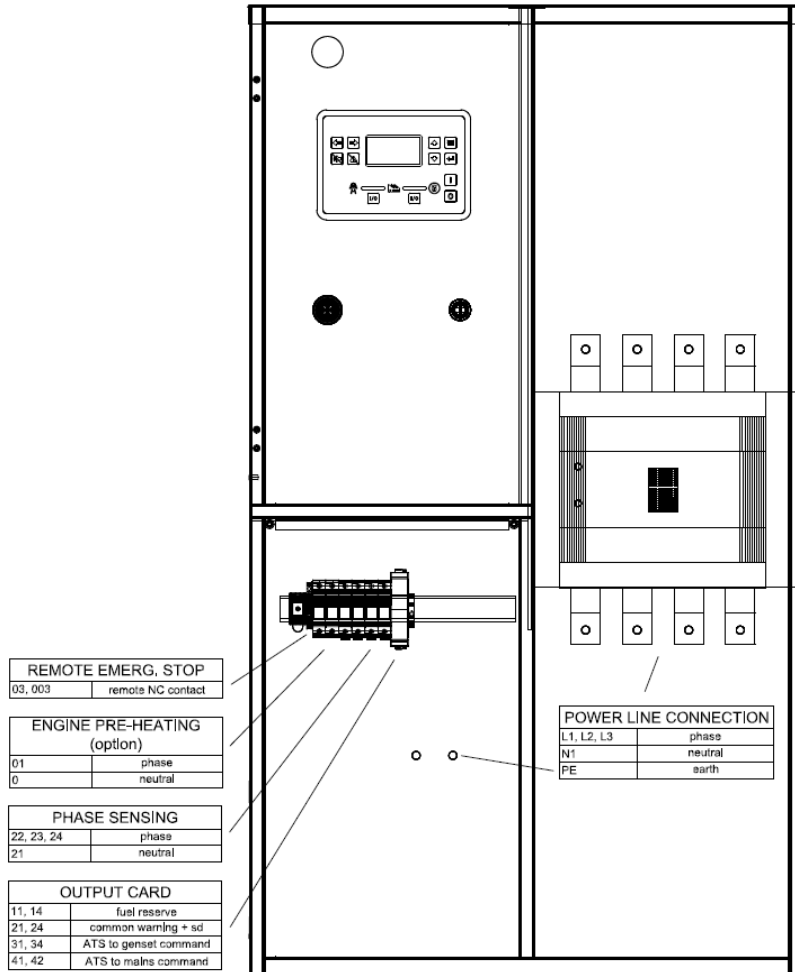

7. Commissioning and start-up

Do not start-up, perform maintenance, repairs or alterations without adequate training. All the operations must be performed in compliance with the safety standards and by qualified operators.

<p>AUTOMATIC START-UP</p>	<p>THE GENERATING SET CAN START-UP AUTOMATICALLY: this can endanger the maintenance technician who may be working <u>on the unit or on the network connected to it.</u></p>
----------------------------------	------------------------------------------------------------------------------------------------------------------------------------------------------------------------------------

	<p>Certain maintenance and inspection operations, depending on the type of unit, may require temporary works to be carried out at a height. Choose the most suitable equipment to guarantee and maintain safe work conditions, in accordance with applicable regulations. Evaluate using ladders or scaffolding for a work station at a height, as well as the use of ropes for access and positioning systems.</p>
--	---------------------------------------------------------------------------------------------------------------------------------------------------------------------------------------------------------------------------------------------------------------------------------------------------------------------------------------------------------------------------------------------------------------------

	<p>Do not climb on the radiator, motor, alternator, canopy or the control panel.</p>
--	--------------------------------------------------------------------------------------

Depending on the equipment, your specific unit may or may not have the battery switch to quickly disconnect the starter batteries. The battery switch is located near the starter batteries or mounted on the battery itself.



Battery switch



Battery switch mounted on the battery itself



Battery switch on bracket

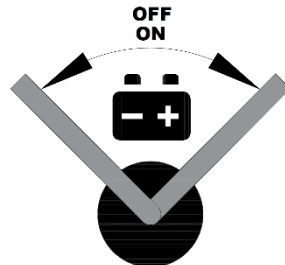

Turn the lever clockwise or counterclockwise. Be sure to bring the lever up to its end (do not linger in intermediate positions).



	<p>The lever can be removed both in the ON position and in the OFF position. Act on the lever only when the machine is switched off (engine stopped and key of the control panel in OFF position and removed).</p>
--	--------------------------------------------------------------------------------------------------------------------------------------------------------------------------------------------------------------------

	<p>Depending on the model of battery switch installed, the lever can be of the type removable in both positions: ON (battery connected) and OFF (battery disconnected). The presence or absence of the lever does NOT imply that the batteries are connected or disconnected.</p> <p>Before any action:</p> <ol style="list-style-type: none"> check if this activity can cause untimely starts (for example due to the presence of maintenance personnel on the machine or on the system connected to it) or the putting out of service the machine in particularly critical emergency applications (e.g. danger for human lives, feeding of hospitals, etc...); the machine must be switched off (engine stopped and key of the control panel in the OFF position and removed). <p>Before acting on the battery switch lever, check if it is in the ON or OFF position: <u>check with a tester the presence of voltage between the positive (+) terminal of the battery and a ground point on the motor.</u></p> <ul style="list-style-type: none"> presence of voltage: battery connected (ON); absence of voltage: battery disconnected (OFF). <p>All operations must be implemented only by qualified and authorized personnel.</p>
--	------------------------------------------------------------------------------------------------------------------------------------------------------------------------------------------------------------------------------------------------------------------------------------------------------------------------------------------------------------------------------------------------------------------------------------------------------------------------------------------------------------------------------------------------------------------------------------------------------------------------------------------------------------------------------------------------------------------------------------------------------------------------------------------------------------------------------------------------------------------------------------------------------------------------------------------------------------------------------------------------------------------------------------------------------------------------------------------------------------------------------------------------------------------------------------------------------------------------------------------------------------------------------------------------------------

Depending on the machine equipment, the percentage of fuel present in the tank may be shown in the control panel display (refer to the control device manual for details).

	<p>When the displayed percentage reaches 0%, the tank still contains a certain amount of fuel (about 10-20% of the nominal capacity of the tank, depending on the specific equipment of your machine). This precaution serves to ensure that a minimum quantity of fuel is always present in the tank so that the engine does not suck up air when the level is very low. In addition, the machine always works in a safety situation, signaling in advance the need for refueling.</p>
	<p>The level sensors have an accuracy of approximately $\pm 10\%$; for this reason, the percentage displayed on the display can not be considered effective in such cases where a high accuracy of the reading is required (for example for tax purposes).</p>
	<p>If there are specific needs different from the above, you can choose other optional equipment. Consult a DEUTZ representative.</p>

7.1. Commissioning

This Paragraph is reserved for qualified technicians who are specifically authorised by DEUTZ, and not the user, to commission the genset. The user must solely carry out the inspections described in Paragraph 0. Starting-up the unit after being stored or not used for a period of time (over 30 days) must be considered equivalent to commissioning.

A few inspections must be performed for the commissioning procedure. Hereunder is a list of typical inspections; depending on the type of set up and system, a few of these may not be required or additional checks that are not listed below may be required.

	<p>It is important for the genset to be switched off and prevent it from being started up before performing any maintenance or inspection on it or the system it is connected to.</p> <ol style="list-style-type: none"> 1. stop the unit and open the unit switch; 2. set the key to the OFF position and remove it from the control panel; 3. wait for the unit to cool down; 4. disconnect the starter batteries; 5. disconnect the power by disconnecting the unit from any source of power, such as pre-heating systems, network detection systems, battery charger, etc. Then open the disconnectors inside the panel on board the unit.
-----------------------------------------------------------------------------------	---------------------------------------------------------------------------------------------------------------------------------------------------------------------------------------------------------------------------------------------------------------------------------------------------------------------------------------------------------------------------------------------------------------------------------------------------------------------------------------------------------------------------------------------------------------------------------------------------------------------------------------------------------------------------------------------------

INSPECTIONS performed with the motor OFF	
Description of the inspection	Performed
Lubricating oil level in the sump	<input type="checkbox"/>
Coolant level in the radiator	<input type="checkbox"/>
Accumulator electrolyte liquid level / state of terminals	<input type="checkbox"/>
Fan belt state and tension	<input type="checkbox"/>
Air filter cartridges state and cleaning	<input type="checkbox"/>
Genset state and general cleaning (motor/alternator/panel)	<input type="checkbox"/>
No lubricant leaks	<input type="checkbox"/>
No fuel leaks	<input type="checkbox"/>
No coolant leaks	<input type="checkbox"/>
Pre-heater efficiency	<input type="checkbox"/>
Tightening of the power and control cables in the relative terminals	<input type="checkbox"/>
Tightening of the protections	<input type="checkbox"/>
Tightening of the clamps (on sleeves and supply pipes)	<input type="checkbox"/>
Seal insulation of the alternator	<input type="checkbox"/>

INSPECTIONS performed with the motor ON with no electrical load	
Description of the inspection	Performed
Manual start-up and stop controls operation	<input type="checkbox"/>
Test start-up and stop cycle operation	<input type="checkbox"/>
Automatic start-up and stop cycle operation	<input type="checkbox"/>
Motor and alternator operation (verify the electrical parameters)	<input type="checkbox"/>
Emergency stop operation	<input type="checkbox"/>
Maximum temperature alarm operation	<input type="checkbox"/>
Maximum oil pressure alarm operation	<input type="checkbox"/>
Alarm operation (according to the specific genset features)	<input type="checkbox"/>
Battery charger device operation (if present)	<input type="checkbox"/>
Fuel topping-up device operation (if present)	<input type="checkbox"/>

INSPECTIONS performed with the motor ON with electrical load (controls subject to the capacity of the Customer's system).	
Description of the inspection	Performed
Manual or automatic start-up cycle operation while charging (check the electrical parameters: voltage, frequency, current)	<input type="checkbox"/>
Maximum power supplied	<input type="checkbox"/>

7.2. Inspections to be performed by the user

Once commissioned, the user must perform the inspections described in this Paragraph on the unit. The user must particularly verify that the routine maintenance is performed (see Chapter 8).

	The frequency of the operations listed below is purely indicative. Every motor and alternator manufacturer require specific maintenance and inspection intervals for each model: always consult the motor and alternator operation and maintenance manuals.
--	--------------------------------------------------------------------------------------------------------------------------------------------------------------------------------------------------------------------------------------------------------------------

	The user must only carry out the inspections described in Paragraph 0. The attached documentation contains additional information regarding the activities that must not be performed unless by personnel who have been authorised by DEUTZ. Before each intervention consult the attached documentation as it relates solely to the operations listed in this paragraph.
--	----------------------------------------------------------------------------------------------------------------------------------------------------------------------------------------------------------------------------------------------------------------------------------------------------------------------------------------------------------------------------------

If the manuals delivered together with the unit indicate different requirements for the same topic, follow the safest and strictest ones.

	Do not clean the GENSET with thinner, alcohol, acid or other aggressive products. Do not use pressure washers on electrical and electronic parts such as the alternator, electrical panel, electronic control units of the motor, etc.
--	-----------------------------------------------------------------------------------------------------------------------------------------------------------------------------------------------------------------------------------------------

	Do not perform repairs autonomously on the generating set during the warranty period. The warranty will be rendered null and void if the products are repaired with no authorisation. Use only original spare parts.
--	-----------------------------------------------------------------------------------------------------------------------------------------------------------------------------------------------------------------------------

	<p>It is important for the genset to be switched off and prevent it from being started up before performing any maintenance or inspection on it or the system it is connected to.</p> <ol style="list-style-type: none"> 1. stop the unit and open the unit switch; 2. set the key to the OFF position and remove it from the control panel; 3. wait for the unit to cool down; 4. disconnect the starter batteries; 5. disconnect the power by disconnecting the unit from any source of power, such as pre-heating systems, network detection systems, battery charger, etc. Then open the disconnectors inside the panel on board the unit.
--	---------------------------------------------------------------------------------------------------------------------------------------------------------------------------------------------------------------------------------------------------------------------------------------------------------------------------------------------------------------------------------------------------------------------------------------------------------------------------------------------------------------------------------------------------------------------------------------------------------------------------------------------------------------------------------------------------

It is very important to view any messages that appear on the control device display in order to keep the unit perfectly efficient; if warnings or faults appear, immediately request support from a DEUTZ authorised technician. The warnings are often preventive alerts of a possible anomaly and disruptions and product faults are prevented if immediate intervention is implemented.

COMPONENT	OPERATIONS TO BE PERFORMED	ANNUAL USE				
		Emergency (≤ 500 h)		Continuous (> 500 h)		
		Before the periodic test (at least every 7 days)	At least every 30 days At least every 12 months	Before starting-up or the periodic test	At least every 30 days	At least every 12 months
	CHECKING THE MESSAGES ON THE CONTROL DEVICE	X		X		
Generating set	General visual inspection that the parts are intact.	X		X	X	
	Visual check that there are no liquid leaks inside the unit compartment and the room of installation.	X		X	X	
	Check that the intake and extraction grilles are clean.	X		X	X	
	Check that the radiating mass is clean.	X		X	X	
	Verify that the lifting points are intact.		X			X
Base Frame	Verify that the safety stickers are intact.		X			X
	Check the tightening of the damper anti-vibration bolts.		X			X
Engine	Check the oil level (*).	X		X	X	
	Check the coolant level (*).	X		X	X	
	Visual check of the wear of the fan belt.	X		X	X	
	Check whether there is water in the diesel pre-filter (** check the tank).	X		X	X	
	Check whether the air filter is clogged and clean.	X	X	X	X	
Fuel	Verify the amount of diesel in the fuel tank. Top up, if necessary.	X		X		
	Verify that there are no leaks from the tank and motor supply circuit.	X		X	X	
	Check whether there is water in the tank (** in the pre-filter).		X		X	
Alternator	Visual check that the alternator parts and power cables are intact.	X		X		X
Electrical panel	Visual check that the components, instruments, switches, differential switches, protections and accessories are intact.	X		X		
	Differential switch test (if supplied)		X		X	
Battery	Visual check that there are no electrolyte leaks.	X		X	X	
	Check the battery liquid level (excluding GEL batteries)		X	X	X	

* Use liquid with the characteristics required by the motor manufacturer.
 ** Related operations

7.3. Starting up and Stopping

	<p>CONSULT THE MANUAL of the control and protection device installed on the genset before starting up the unit. The information found below regarding the various control systems produced by DEUTZ is only a summary of the basic functions described in the relative manual and are not enough to use the device itself or for the operator to be sufficiently informed on using the genset.</p> <p>The genset is a unit intended to be used by duly trained personnel. Errors when installing or using the unit can seriously damage the user system, the unit itself or injure those involved.</p>
--	--------------------------------------------------------------------------------------------------------------------------------------------------------------------------------------------------------------------------------------------------------------------------------------------------------------------------------------------------------------------------------------------------------------------------------------------------------------------------------------------------------------------------------------------------------------------------------------------------------------------

 	<p>There can be hazardous voltages inside the generating set and the control board even with the genset switched off: do not start-up, perform maintenance, repairs or alterations without specific knowledge or precise guidelines. All the operations must always be performed in compliance with the safety standards.</p> <p>ATTENTION: Starting and stopping the motor with the power supply connected can damage the generating set and the user system.</p> <p>ATTENTION: before selecting the AUTO or TEST modes make sure the genset cannot be started inadvertently due to a programming or connection error.</p>
----------	-------------------------------------------------------------------------------------------------------------------------------------------------------------------------------------------------------------------------------------------------------------------------------------------------------------------------------------------------------------------------------------------------------------------------------------------------------------------------------------------------------------------------------------------------------------------------------------------------------------------------------------------

MAKE SURE THE MAIN SWITCH IS OPEN (OFF)

	<p>Set the ignition key to the 1/ON position to switch the device on (see the figure at the side).</p>
--	--------------------------------------------------------------------------------------------------------

	<p>If the unit must be blocked in an emergency use the relative mushroom button. To stop the unit regularly, use the controls indicated in the manual of the control board. Use the mushroom button only in an emergency.</p>
--	--------------------------------------------------------------------------------------------------------------------------------------------------------------------------------------------------------------------------------------------------------------

	<p>Digital control and protection device designed for the genset to be used in various operating modes:</p> <ul style="list-style-type: none"> • Manual mode (basic version); • Automatic remote mode (optional); • Automatic mode due to power failure (optional); • Automatic tank filling mode (optional); • Special modes to be added to the standard modes, on request.
--	---------------------------------------------------------------------------------------------------------------------------------------------------------------------------------------------------------------------------------------------------------------------------------------------------------------------------------------------------------------------------------------------------------------------------------

On the main page, press or to switch the OFF, MAN, AUTO or TEST modes.

When the device is in MAN mode (manual), the genset can be started or stopped via the / keys

8. Maintenance

Do not start-up, perform maintenance, repairs or alterations without adequate training. All the operations must be performed in compliance with the safety standards and by qualified operators. Moreover:

<p>AUTOMATIC START-UP</p>	<p>THE GENERATING SET CAN START-UP AUTOMATICALLY: this can endanger the maintenance technician who may be working on the unit or on the network connected to it.</p>
	<p>It is important for the genset to be switched off and prevent it from being started up before performing any maintenance or inspection on it or the system it is connected to.</p> <ol style="list-style-type: none"> 1. stop the unit and open the unit switch; 2. set the key to the OFF position and remove it from the control panel; 3. wait for the unit to cool down; 4. disconnect the starter batteries; 5. disconnect the unit from any source of power, such as pre-heating systems, network detection systems, battery charger, etc. Then open the disconnectors inside the panel on board the unit.

	<p>Do not clean the genset with thinner, alcohol, acid or other aggressive products. Do not use pressure washers on electrical and electronic parts such as the alternator, electrical panel, electronic control units of the motor, etc.</p>
--	------------------------------------------------------------------------------------------------------------------------------------------------------------------------------------------------------------------------------------------------------

	<p>Certain maintenance and inspection operations, depending on the type of unit, may require temporary works to be carried out at a height. Choose the most suitable equipment to guarantee and maintain safe work conditions, in accordance with applicable regulations. Evaluate using ladders or scaffolding for a work station at a height, as well as the use of ropes for access and positioning systems.</p>
--	---------------------------------------------------------------------------------------------------------------------------------------------------------------------------------------------------------------------------------------------------------------------------------------------------------------------------------------------------------------------------------------------------------------------

	<p>Do not climb on the radiator, motor, alternator, canopy or the control panel.</p>
--	--------------------------------------------------------------------------------------

8.1. Genset maintenance

The maintenance operations described in this paragraph must only be performed by qualified personnel. The User must contact a DEUTZ technician.

Refer to the motor and alternator manuals supplied together with the unit. **If the manuals delivered together with the unit indicate different requirements for the same topic, follow the safest and strictest ones.**

OPERATION	FREQUENCY OF OPERATIONS
Replacing the fuel cartridge	Refer to the engine manual
Replacing the oil* of the sump, oil cartridges and air filter	Refer to the engine manual
Replacing the coolant*	Refer to the engine manual
Overhauling the injectors	Refer to the engine manual
Cleaning the radiator / checking the sleeves	Before summer, at least once a year
Adjusting the play of the valves and the balancers	Refer to the engine manual
Partial engine overhaul	Refer to the engine manual
Complete engine overhaul	Refer to the engine manual
Checking the alternator bearing/s	Refer to the alternator manual
Checking the insulation of the alternator	Refer to the alternator manual
Replacing the alternator bearing/s	Refer to the alternator manual
Checking the tightness of the nuts and bolts and fittings	At least every 2500 hours or once a year
Replacing the lifting eye bolts and/or the lifting hooks.	At least every 3 years
Replacing the exhaust silencer (only in GX, S or SS versions)	At least every 8000/10000 hours or every 3 years
Cleaning the tank and retention basin	At least every 2500 hours or once a year
Replacing the sound-proofing material of the canopy	At least every 10000 hours or 3 years

* Use liquid with the characteristics required by the motor manufacturer.

	<p>Do not perform repairs autonomously on the generating set during the warranty period. <u>The warranty will be rendered null and void if the products are repaired with no authorisation.</u> Use only original spare parts.</p>
--	-------------------------------------------------------------------------------------------------------------------------------------------------------------------------------------------------------------------------------------------

8.2. Periodic operation test

The periodic test is used to verify that the genset is working correctly and prevents downtime due to the unit not being used. Of course, this does not mean the user is not required to perform a direct inspection of the genset.

	<p>DANGER: before enabling the periodic tests:</p> <ul style="list-style-type: none"> - make sure the unit start-up does not generate hazardous situations for any maintenance technician, operator or user who are working <u>on the unit or the network connected to it</u>; - if the generating set is used in particularly critical emergency situations, consider that the periodic test can cause the power supply to the load to be temporarily suspended.
-----------------------------------------------------------------------------------	--------------------------------------------------------------------------------------------------------------------------------------------------------------------------------------------------------------------------------------------------------------------------------------------------------------------------------------------------------------------------------------------------------------------------------------------------------------------------------------------------

It is recommended to perform the periodic test with the load connected (periodic test with load) as this guarantees greater reliability; if this is not possible, perform the test on empty. Perform a test with load for 60 minutes at least once every 6 months, always setting the date of the tests in the middle of the working week so as to always be able to be given technical support.

The frequencies for the indicated operating tests are to be considered as the minimum required. If the genset is used in particularly critical situations, consider performing the tests at shorter intervals.

Once the test is complete, always verify the possible presence of messages on the genset display and request immediate technical support.

For manual units, the periodic tests must be performed and managed manually by an operator. For automatic units, the periodic tests can be managed autonomously by the generating set by enabling the setting on the control panel. In both cases, it is compulsory for the operator to be present during the test in order to verify any anomaly. Perform the operations described in Paragraph 0 before the test.

OPERATION	FREQUENCY OF OPERATIONS
Performing the periodic test: <i>operating the unit for at least 10 minutes</i>	At least every 7 days
Performing the half-yearly test: <i>operating the loaded unit for 60 minutes</i>	At least once every 6 months

Consult the user instructions of the control panel installed on your unit for the settings procedure. Verify any warnings or alarms during the test, which are resolved by requesting the intervention of a service centre or a DEUTZ technician.

8.3. Troubleshooting

Always refer to the warnings indicated by the control device and the relative manual for faults or malfunction.

	<p>The user must only carry out the inspections described in Paragraph 0. The attached documentation contains additional information regarding the activities that must not be performed unless by personnel who have been authorised by DEUTZ. Before each intervention consult the attached documentation as it relates solely to the operations listed in this paragraph.</p>
-------------------------------------------------------------------------------------	----------------------------------------------------------------------------------------------------------------------------------------------------------------------------------------------------------------------------------------------------------------------------------------------------------------------------------------------------------------------------------

Hereunder are the main faults that may be detected by the control device.

PROBLEM	PROBABLE CAUSES
The control device does not go on	flat battery
	disconnected battery
	interrupted batter power supply circuit
	blown fuse
Circuit breaker does not close	short circuit on the line
	dispersion on the line (triggered differential switch)
	overload
	release coil fault
The starter turns slowly or gets blocked	flat batteries
	faulty starter motor
The starter motor attempts to start up but the genset does not start	low fuel level
	clogged diesel filter
	air in the diesel circuit
	clogged air filter
	diesel circuit is disengaged
	low room temperature

Contact the service centre as described in Chapter 9 for any problem that may occur.

9. Requesting assistance

You are kindly asked to proceed as follows when providing the necessary information so as to reduce DEUTZ service centre intervention times and allow the problems to be easily resolved:

1. Take note of the messages on the display to communicate these to the technician
2. Try to identify the cause of the fault by referring to the above mentioned table;
3. Contact an authorised DEUTZ dealer while having the following readily available:
 - Genset data shown on the plate applied on the unit;
 - Details of the purchase note/invoice (if the genset data shown on the plate are not available);
 - Company name or that of who made the purchase;
 - Dealer name (only in the case of direct contact with DEUTZ offices);
 - A description of the fault with as many details as possible on the probable cause, any incorrect manoeuvres and improper uses;
 - The message that appears on the control panel;

Remember that the warranty validity restrictions are found in the contract documents and the warranty certificate, provided at the time of purchase. In particular, DEUTZ cannot be held liable in the case of damage caused by improper use or overload; incorrect or lack of maintenance; any alteration or replaced parts with spare parts that are not approved by DEUTZ or the parts manufacturer.

10. Storage instructions

Hereunder are the operations to be performed on the components of the unit before being stored in order to prevent deterioration. When not used for long periods of time (over 30 days), consult the operation and maintenance instructions of the motor and alternator together with the other instruction files possibly provided together with the unit (specific chapters regarding the requirements for correct storage).

Moreover:

- Empty the fuel tank completely;
- Thoroughly clean the unit and protect it against dust and humidity with a cover;
- Disconnect the starter battery and verify its charge every 2 months;
- Protect the terminals of the connection cables to the battery with specific grease;
- Disconnect the cables of the auxiliary devices from the terminal block of the electrical panel and make sure that the panel is adequately protected against dust and humidity when stored, whilst guaranteeing necessary ventilation so as not to form condensation.



Note: use only products and additives approved by the motor manufacturers. After having performed the described operations, place the generating set indoors, in a dry, cool place.

11. Disposal instructions

All the components of the generating set are to be disposed of as special waste. The battery and the liquids contained in the motor are hazardous waste. It is recommended to comply with all the applicable laws in the place of disposal.

At the end of use of the equipment or in the case of demolition, it must be disposed of according to the requirements of applicable laws in the destination country.

The identification labels of the genset and any other relative document should also be destroyed.

For the disposal of the generating set, applicable laws and regulations inherent the managing of the waste by qualified subjects must to be considered (preferably call on companies specialized in the recovery of industrial vehicles / engines).